

Fieldstone Octagon Tower

All blocks used on this brace are from mold #70

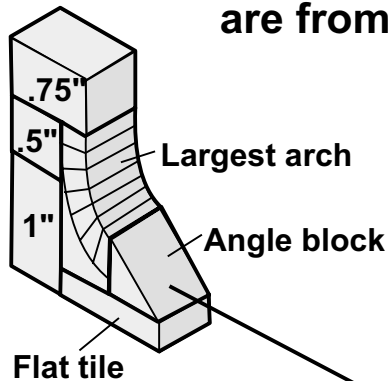

Make 8 of these

All blocks used on this wall are from mold #77

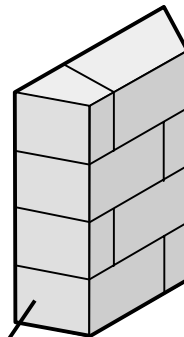

Make 7 of these

-  Light blocks are from mold #70
-  Dark blocks are from mold #77

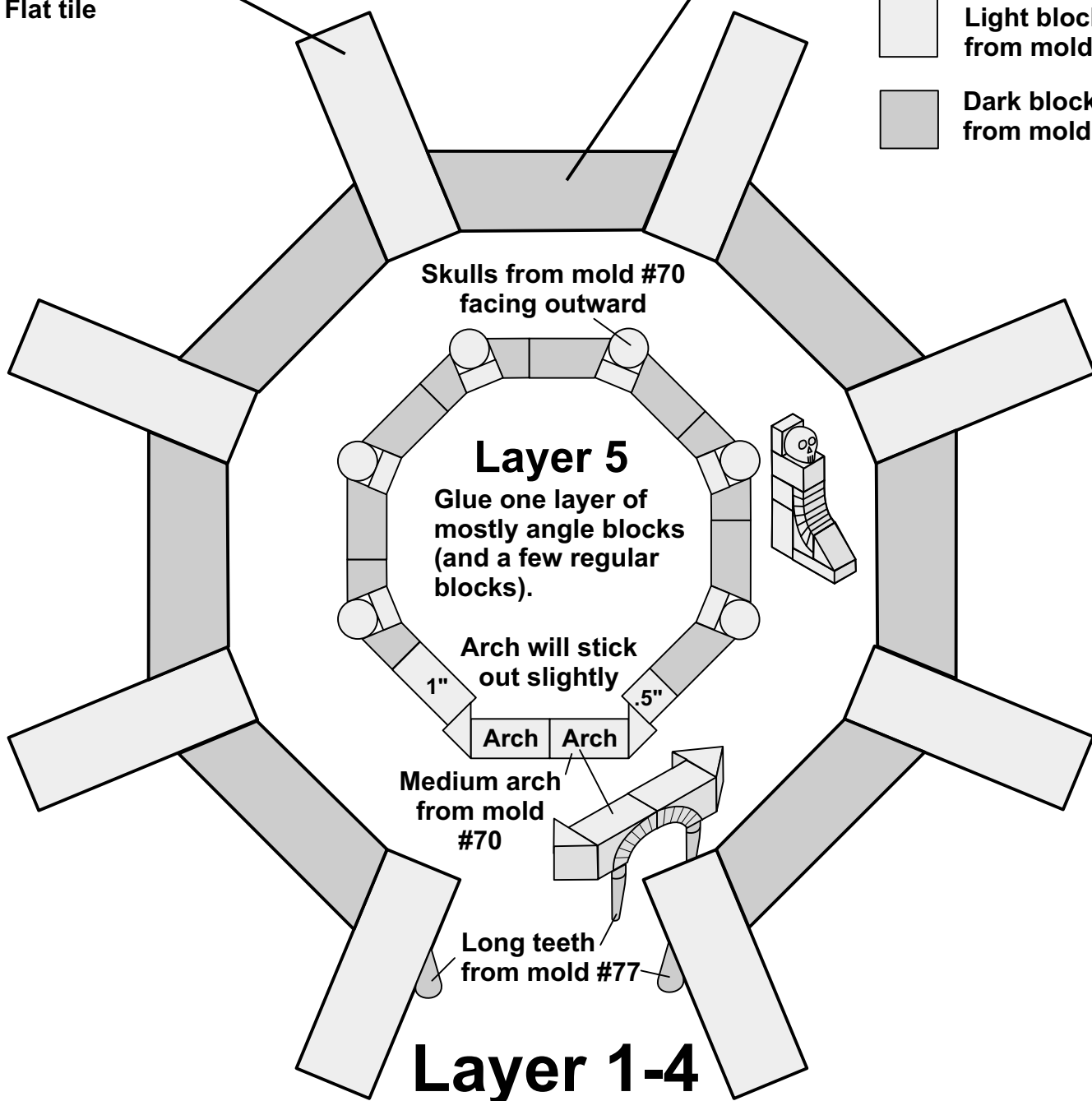

Layer 1-4

Layers 1-4 are made by gluing the 8 leg braces and the 7 angled wall sections together. Set them on this plan and glue them around in a circle leaving a gap for the doorway.

Fieldstone Octagon Tower

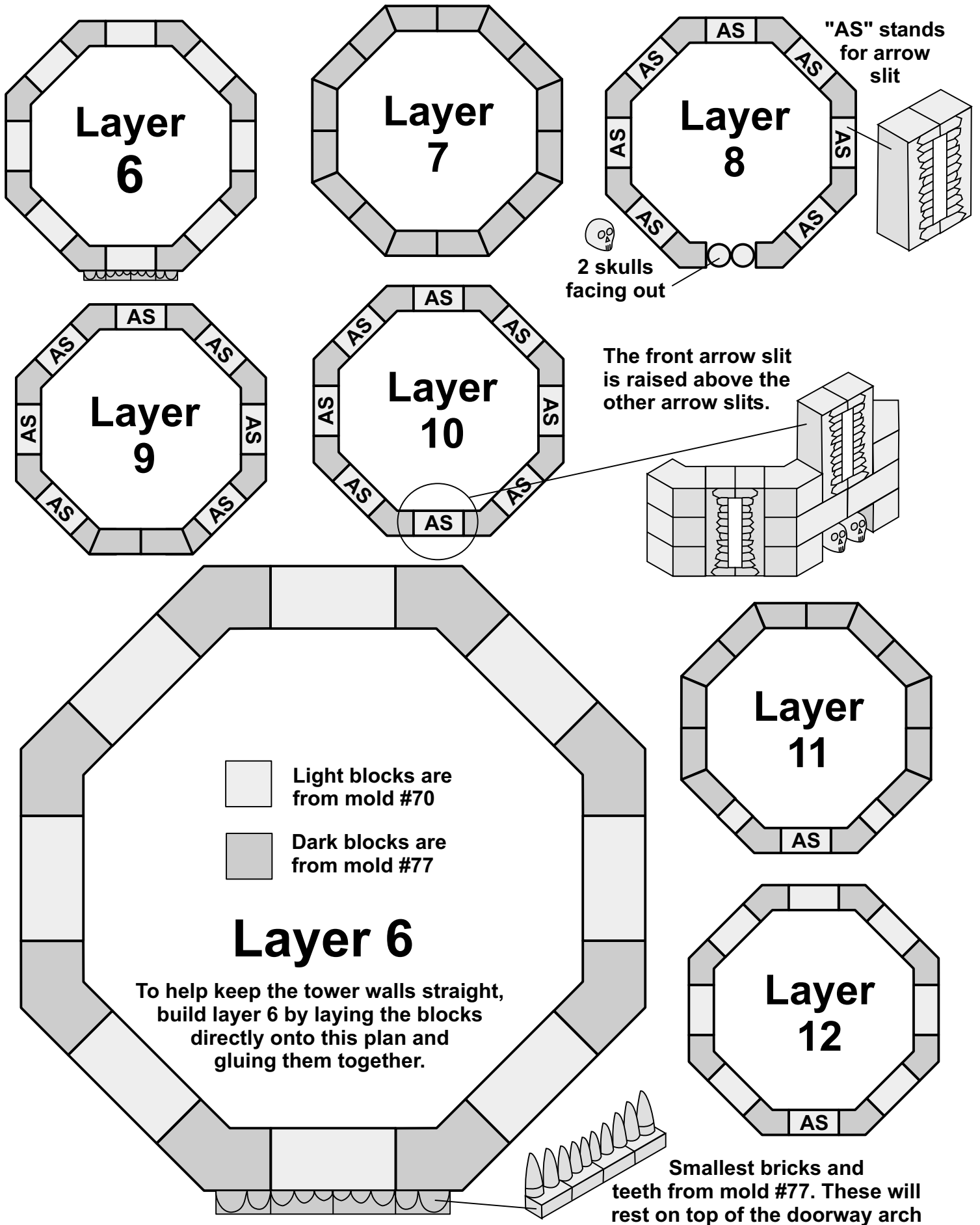

Fieldstone Octagon Tower

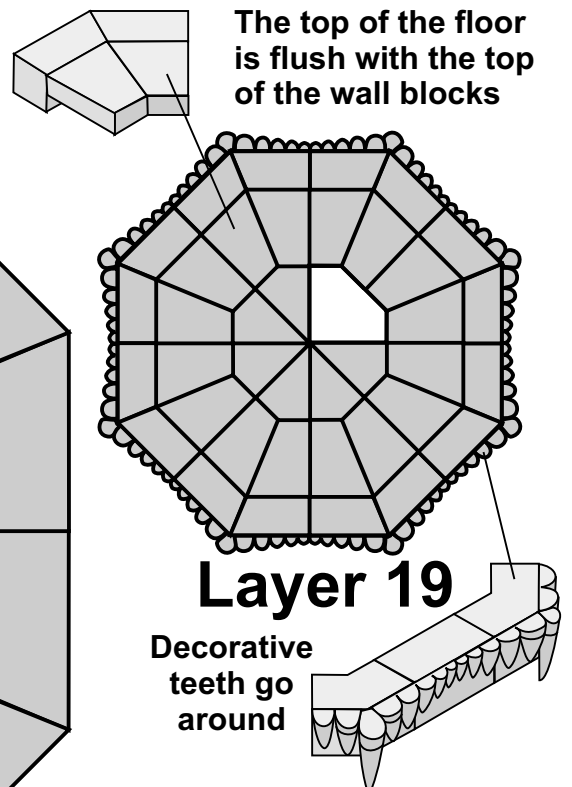
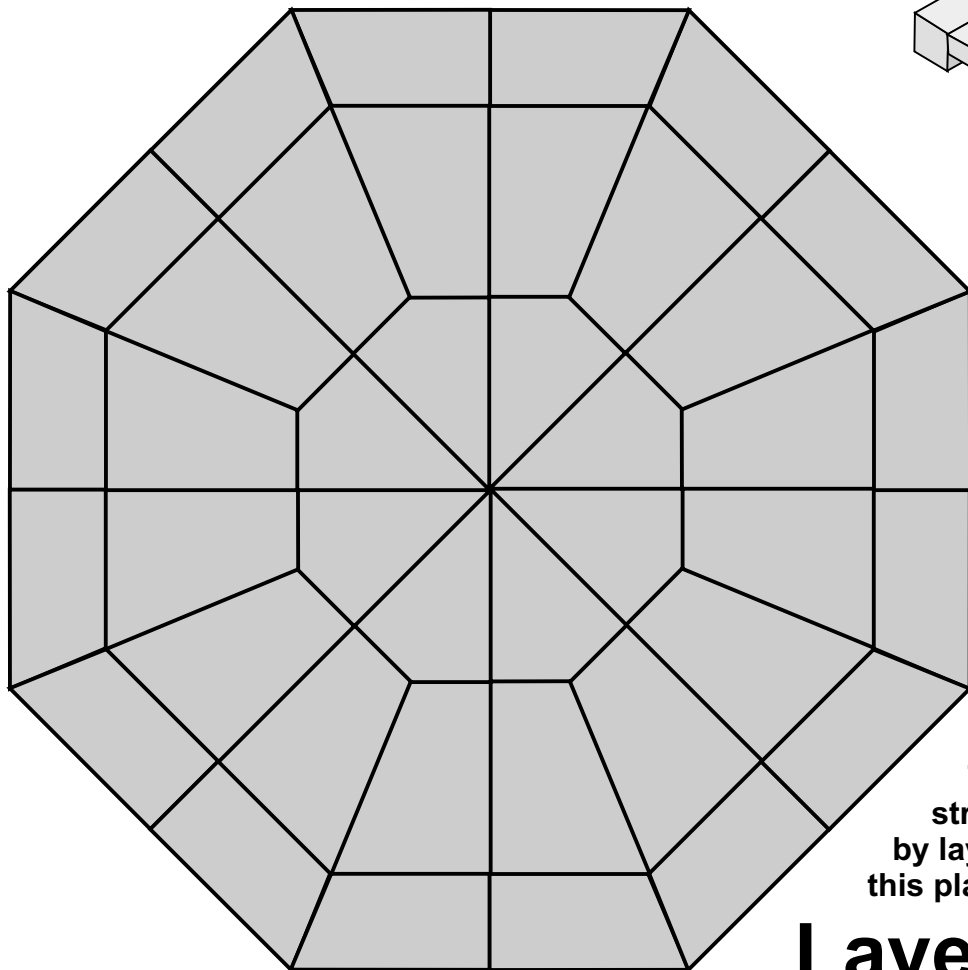
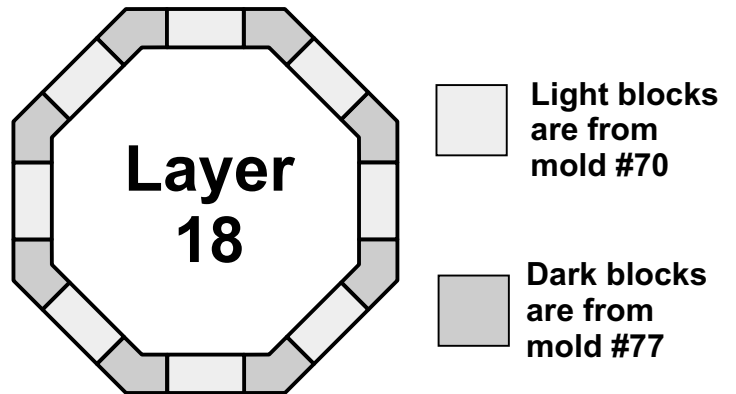
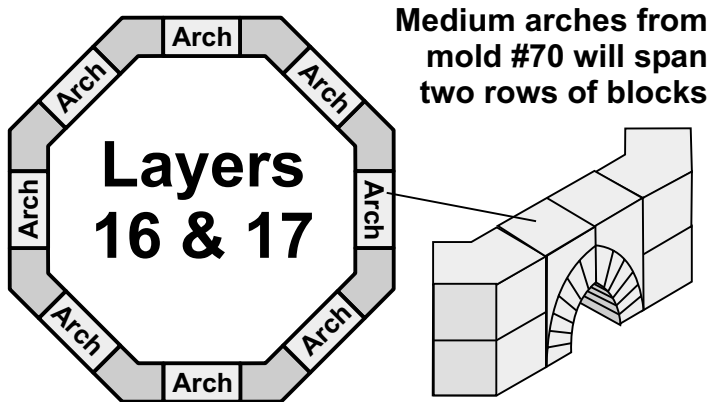
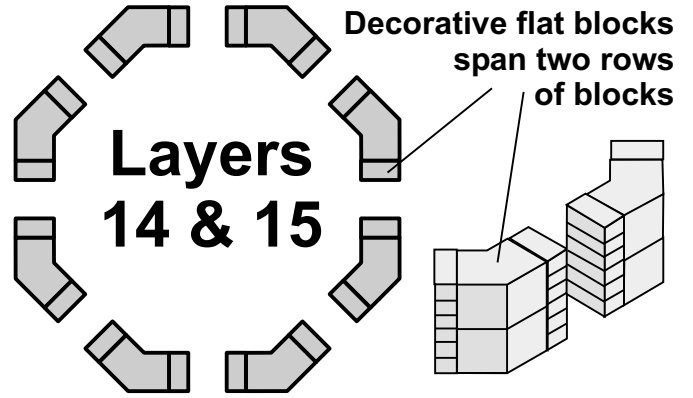
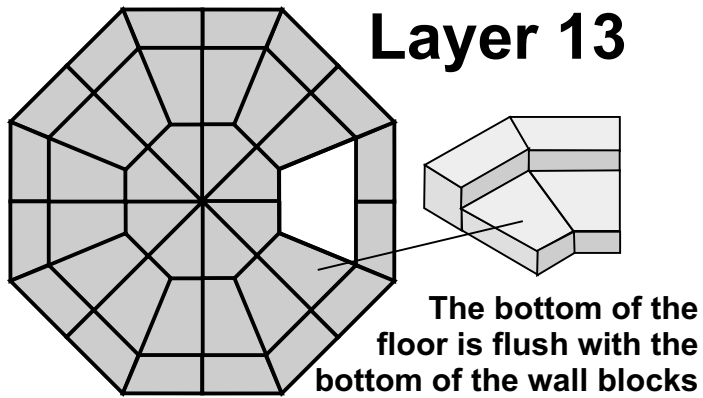

To help keep the tower walls straight, build layers 13 and 19 by laying the blocks directly onto this plan and gluing them together.

Layers 13 & 19

Fieldstone Octagon Tower

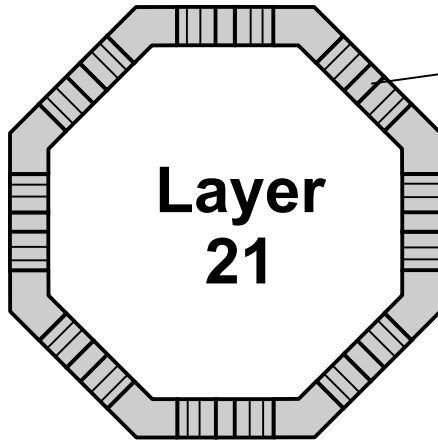
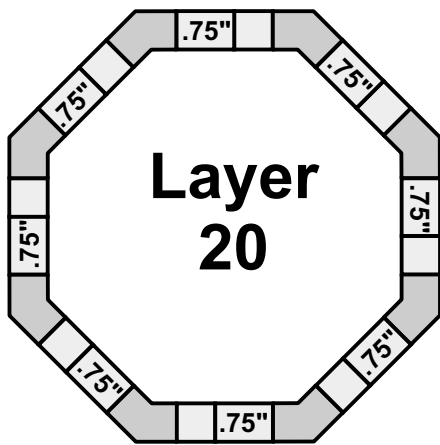

Rounded teeth go on top

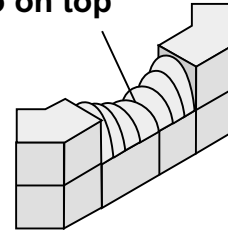

Large teeth cap off the very top of the tower

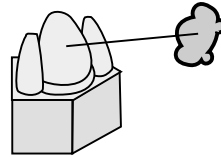

Layer 22

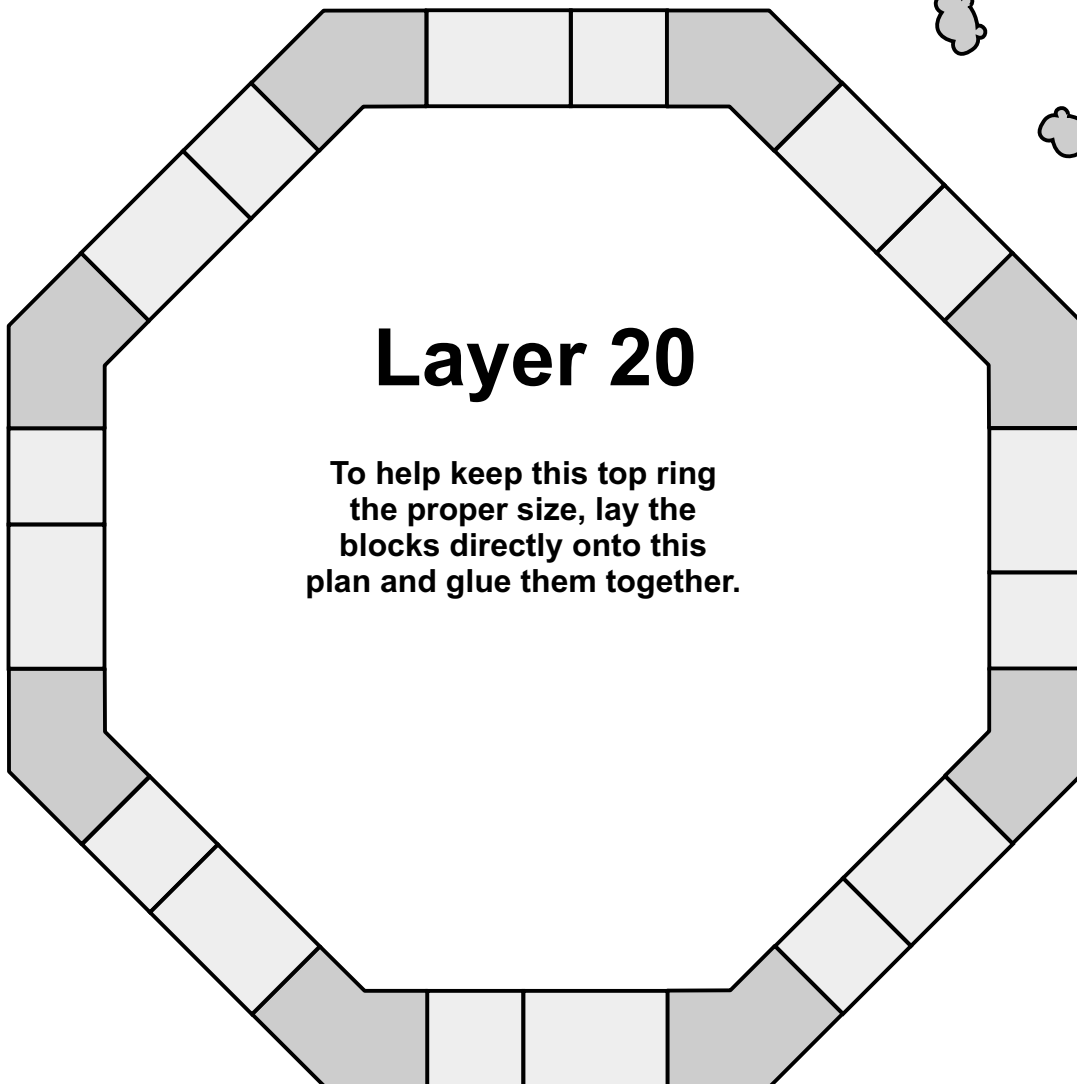

To help keep this top ring the proper size, lay the blocks directly onto this plan and glue them together.

Light blocks are from mold #70

Dark blocks are from mold #77